

Ignition IGBT

Power Electronics Solution - Contributing to Environment, Safety and Comfort -

■ Features

- Small SMD-Package : D-Pack, D2-Pack
- High-Voltage : $V_{CES}=410[V]$
- Low Saturation Voltage : $V_{CE(sat)}=1.3V @ I_c=5[A]$ (D-Pack)
: $V_{CE(sat)}=1.3V @ I_c=12[A]$ (D2-Pack)
- Gate-Emitter Continuous Voltage : $5[V]$
- Collector-Emitter, Gate-Emitter ESD Protection
- MP starting from 2010

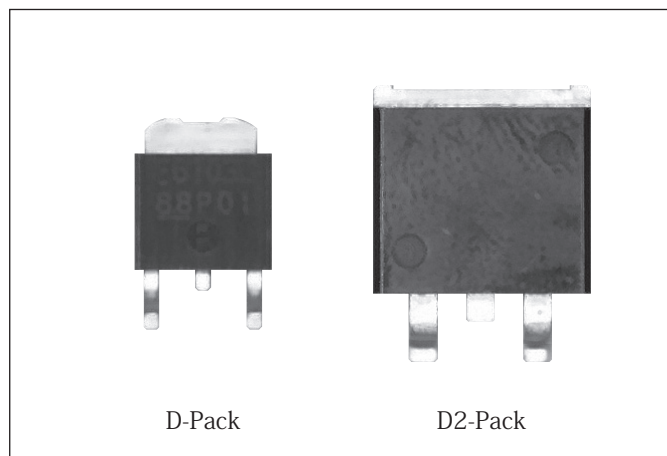

■ Applications

- Ignition Systems

■ Specifications

V_{CES}	410[V]
I_{ces}	0.05[μA]
V_{GEO}	6.5[V]
R_{GE}	20[k Ω]
$-V_{CE}$	30[V]
$V_{GE(th)}$	2[V]
$V_{CE(sat)}$	1.3[V] @ $I_c=5[A]$ (D-Pack) @ $I_c=12[A]$ (D2-Pack)
$SW(OFF)$	12[μs]
ESB	180[mJ], 230[mJ]

● Applications

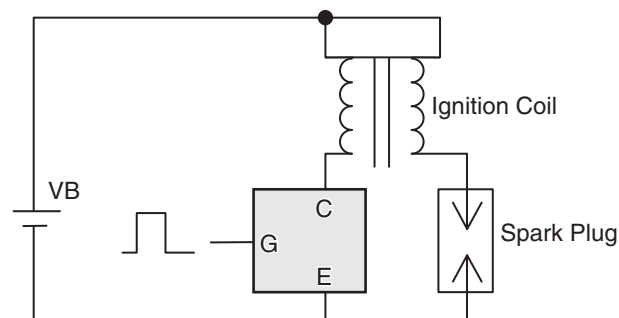

● Symbol

