

---

# Chapter 6

## Cooling Design

---

### CONTENTS

### Page

1. Power dissipation loss calculation .....	6-2
2. Selecting heat sinks .....	6-7
3. Heat sink mounting precautions .....	6-10

This section explains the cooling design.

---

For safe IGBT operation, the junction temperature ( $T_j$ ) must never exceed  $T_j(\max)$ . Therefore, it is necessary to have a cooling design capable of keeping the junction temperature below  $T_j(\max)$ , even during overload conditions.

## 1 Power dissipation loss calculation

### 1.1 Types of power loss

An IGBT module consists of IGBT chips and FWD chips. The sum of the power losses from these sections equals the total power loss for the module. Power loss can be classified as either on-state loss or switching loss. A diagram of the power loss factors is shown as follows.

#### Power loss factors

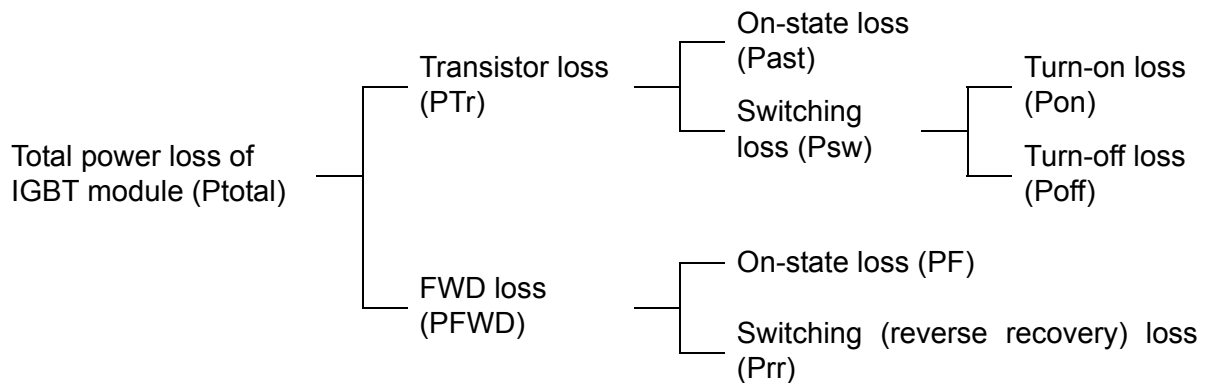

The on-state power loss from the IGBT and FWD sections can be calculated using the output characteristics, while switching loss can be calculated from switching loss vs. collector current characteristics. Use these power loss calculations in order to design cooling sufficient to keep the junction temperature  $T_j$  below the maximum rated value.

The on-voltage and switching loss values to be used here, are based on the standard junction temperature  $T_j$  ( $125^\circ\text{C}$  is recommended).

For characteristics data, refer to the module specification sheets.

### 1.2 DC chopper circuit power loss calculations

For easy approximate calculations, consider the current flowing to the IGBT or FWD as a train of square waves. Fig. 6-1 is a diagram showing the approximate waveforms of a DC chopper circuit. At collector current  $I_c$  the saturation voltage is represented by  $V_{CE(sat)}$  and switching energy is represented by  $E_{on}$  and  $E_{off}$ . At FWD forward current  $I_F$ ,  $V_F$  represents the on-voltage and  $E_{RR}$  represents the energy loss during reverse recovery. Using the above parameters, IGBT power loss can be calculated as follows:

$$\begin{aligned} \text{IGBT power dissipation loss (w)} &= \text{On-state loss} + \text{Turn-on loss} + \text{Turn-off loss} \\ &= \left[ t_1/t_2 \times V_{CE(sat)} \times I_C \right] + \left[ fc \times (E_{on} + E_{off}) \right] \end{aligned}$$

$$\begin{aligned} \text{FWD power dissipation loss (w)} &= \text{On-state loss} + \text{Reverse recovery loss} \\ &= \left[ (1 - (t_1/t_2)) \times I_F \times V_F \right] + \left[ fc \times E_{rr} \right] \end{aligned}$$

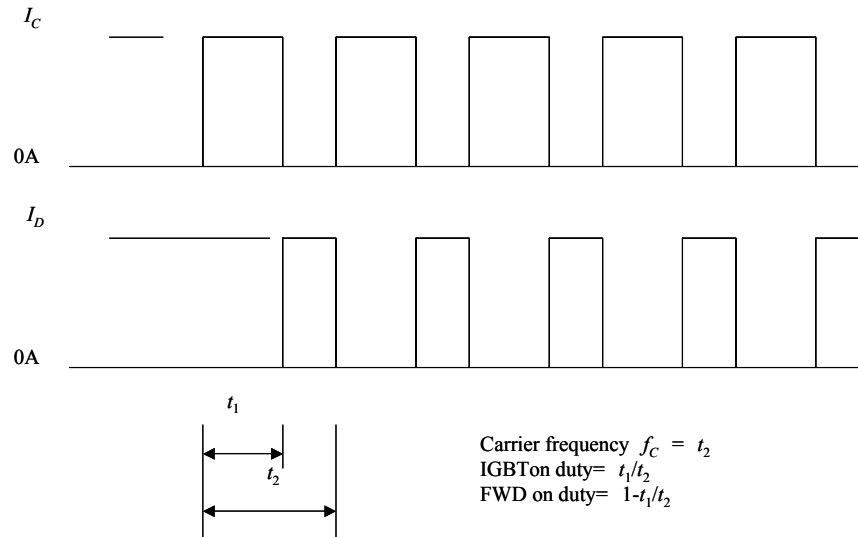

**Fig. 6-1 DC chopper circuit current waveforms**

The DC supply voltage, gate resistance, and other circuit parameters, may deviate from the standard value listed in the module specification sheets. In this event, approximate values can be calculated according to the following rules:

- DC supply voltage  $E_d(VCC)$  deviation
  - On voltage: Not dependent on  $E_d(VCC)$
  - Switching loss: Proportional to  $E_d(VCC)$
  
- Gate resistance deviation
  - On voltage: Not dependent on gate resistance
  - Switching loss: Proportional to switching time and dependent on gate resistance

### 1.3 Sine-wave VVVF inverter application power dissipation loss calculation

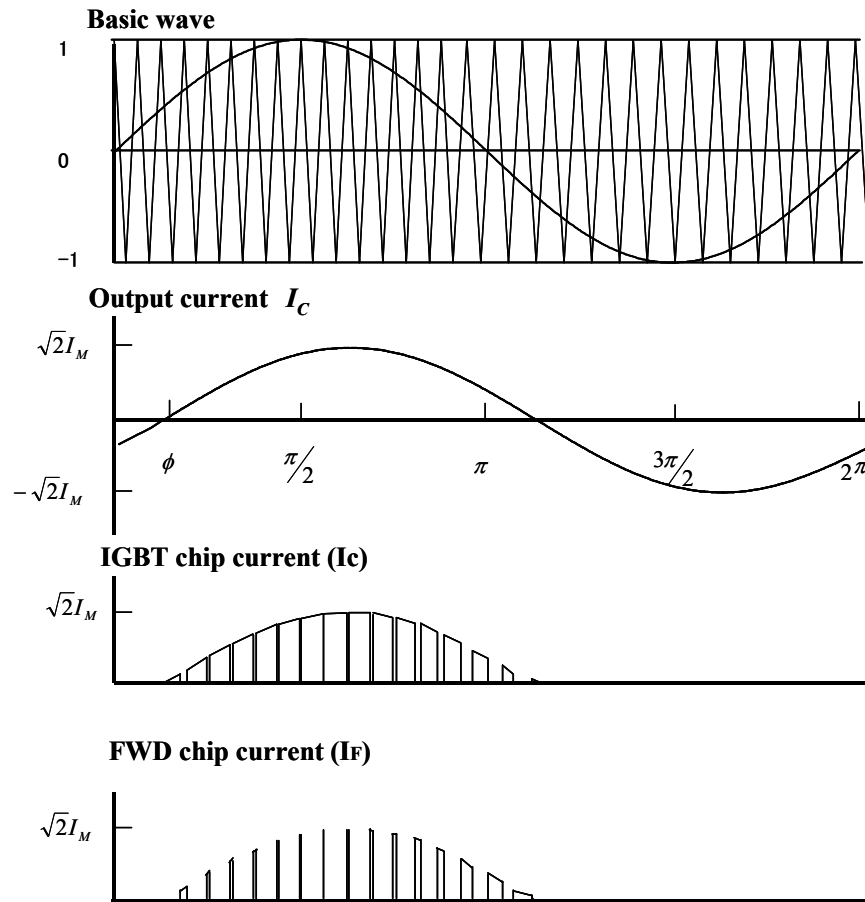

Fig. 6-2 PWM inverter output current

When using a VVVF inverter for a PWM control, the current value and operation keep changing as shown in Fig. 6-2. Therefore, it is necessary to use computer simulations in order to make detailed power loss calculations. However, since computer simulations are very complicated, the following is an explanation of a simple method that generates approximate values.

#### 1) Prerequisites

For approximate power loss calculations, the following prerequisites are necessary:

- Three-phase PWM-control VVVF inverter for sine-wave current output
- PWM control based on the comparison of sine-waves and sawtooth waves
- Output current in ideal sine-wave form

#### 2) Calculating on-state power loss ( $P_{\text{sat}}$ , $P_{\text{F}}$ )

As displayed in Fig. 6-3, the output characteristics of the IGBT and FWD have been approximated based on the data contained in the module specification sheets.

On-state power loss in IGBT chip ( $P_{sat}$ ) and FWD chip ( $P_F$ ) can be calculated as follows:

$$(P_{sat}) = DT \int_0^x I_C V_{CE(sat)} d\theta$$

$$= \frac{1}{2} DT \left[ \frac{2\sqrt{2}}{\pi} I_M V_O + I_{M^2} R \right]$$

$$(P_F) = \frac{1}{2} DF \left[ \frac{2\sqrt{2}}{\pi} I_M V_O + I_{M^2} R \right]$$

DT, DF: Average conductivity of the IGBT and FWD at a half wave of the output current. (Refer to Fig. 6-4)

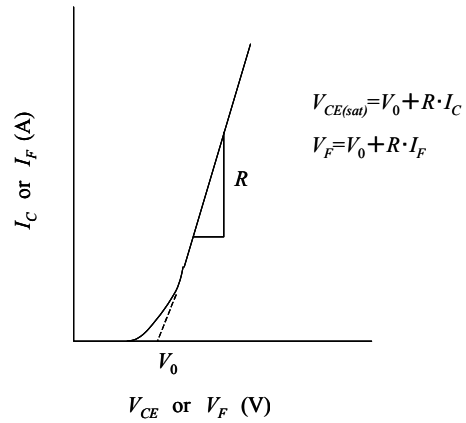

Fig. 6-3 Approximate output characteristics

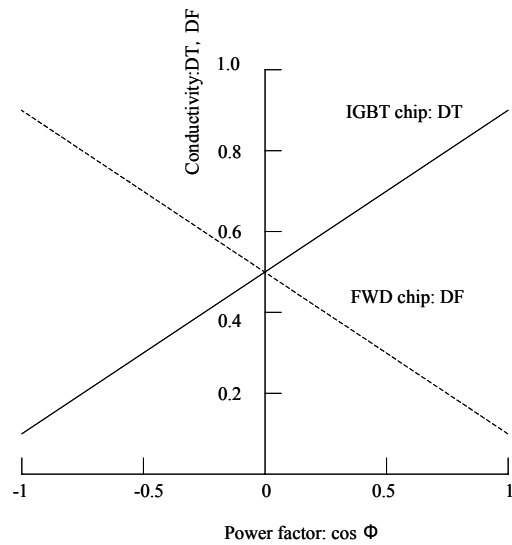

Fig. 6-4 Relationship between power factor sine-wave PWM inverter and conductivity

### 3) Calculating switching loss

The characteristics of switching loss vs.  $I_C$  are generally approximated using the following equations an Fig. 6-5 (Module specification sheet data).

$$E_{on} = E_{on'} (I_C / \text{rated } I_C)^a$$

$$E_{off} = E_{off'} (I_C / \text{rated } I_C)^b$$

$$E_{rr} = E_{rr'} (I_C / \text{rated } I_C)^c$$

a, b, c: Multiplier

Eon', Eoff', Err': Eon, Eoff and Err at rated IC

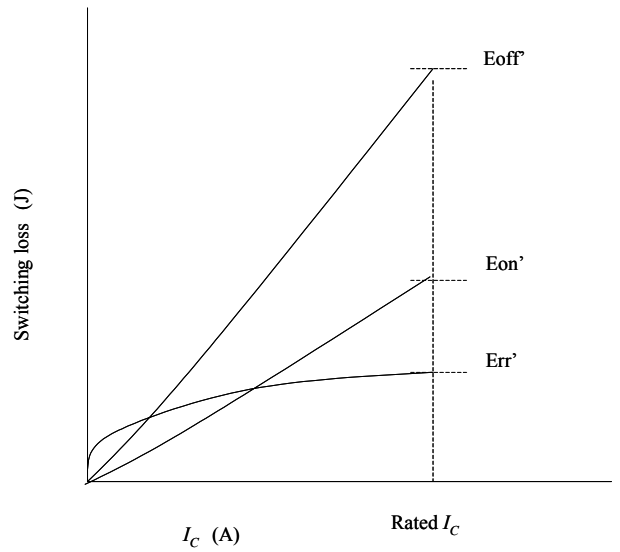

Fig. 6-5 Approximate switching losses

The switching loss can be represented as follows:

#### • Turn-on loss (P<sub>on</sub>)

$$\begin{aligned}
 P_{on} &= fo \sum_{K=1}^n (E_{on})k \quad \left( n: \text{Half - cycle switching count} = \frac{fc}{2fo} \right) \\
 &= fo E_{on'} \frac{1}{\text{rated } I_{C^a}} \sum_{k=1}^n (I_{C^a})k \\
 &= fo E_{on'} \frac{n}{\text{rated } I_{C^a} \times \pi} \int_0^\pi \sqrt{2} I_{M^a} \sin \theta d\theta \\
 &\cong fo E_{on'} \frac{1}{\text{rated } I_{C^a}} n I_{M^a} \\
 &= \frac{1}{2} fc E_{on'} \left[ \frac{I_M}{\text{rated } I_C} \right]^a \\
 &= \frac{1}{2} fc E_{on} (I_M)
 \end{aligned}$$

$$E_{on}(I_M):I_C = E_{on} \text{ at } I_M$$

#### • Turn-off loss (P<sub>off</sub>)

$$P_{off} \cong \frac{1}{2} fc E_{off} (I_M)$$

$$E_{off}(I_M):I_C = E_{off} \text{ at } I_M$$

- **FWD reverse recovery loss ( $P_{rr}$ )**

$$P_{off} \approx \frac{1}{2} f_c E_{rr}(I_M)$$

$$E_{rr}(I_M) : I_c = E_{rr} \text{ at } I_M$$

#### 4) Calculating total power loss

Using the results obtained in section 1.3 subsection 2 and 3.

$$\text{IGBT chip power loss: } P_{Tr} = P_{sat} + P_{on} + P_{off}$$

$$\text{FWD chip power loss: } P_{FWD} = P_F + P_{rr}$$

The DC supply voltage, gate resistance, and other circuit parameters will differ from the standard values listed in the module specification sheets.

Nevertheless, by applying the instructions of this section, the actual values can easily be calculated.

## 2 Selecting heat sinks

Most power diodes, IGBTs, transistors and other power devices are designed to be insulated between electrodes and mounting bases. This type of module can be mounted and wired compactly in a variety of equipment, because several devices can be mounted in a single heat sink. However, in order to ensure safe operation, the power loss (heat) generated by each module must be dissipated efficiently. This is why heat sink selections is very important. The basic of heat sink selection will be illustrated in the following.

### 2.1 Thermal equations for on-state power loss calculations

The heat conduction of a semiconductor can be simulated in an electric circuit. For this example, with only one IGBT module mounted on the heat sink, the equivalent circuit is shown in Fig. 6-6.

Using the above equivalent circuit, the junction temperature ( $T_j$ ) can be calculated using the following thermal equation:

$$T_j = W \times \{R_{th(j-c)} + R_{th(c-f)} + R_{th(f-a)}\} + T_a$$

Note that the case temperature ( $T_c$ ) and heat sink surface temperature mentioned here are measured from the base of the IGBT module directly below the chip. As shown in Fig. 6-7, the temperature measurements at all other points may be low due to the heat dissipation capability of the heat sink, and this needs to be taken into consideration during final heat sink selection. Next, the equivalent circuit of an IGBT (2-pack-module) and a diode bridge mounted on a heat sink is shown in Fig. 6-8. The thermal equations in this case are as follows:

$$T_j(d) = Wd \times [R_{th(j-c)d} + R_{th(c-f)d}] + [(Wd + 2WT + 2WD) \times R_{th(f-a)}] + T_a$$

$$T_j(T) = WT \times R_{th(j-c)T} + [(WT + WD) \times R_{th(c-f)T}] + [(Wd + 2WT + 2WD) \times R_{th(f-a)}] + T_a$$

$$T_j(D) = WD \times R_{th(j-c)D} + [(WT + WD) \times R_{th(c-f)T}] + [(Wd + 2WT + 2WD) \times R_{th(f-a)}] + T_a$$

Use the above equations in order to select a heat sink that can keep the junction temperature ( $T_j$ ) below  $T_{j(max)}$ .

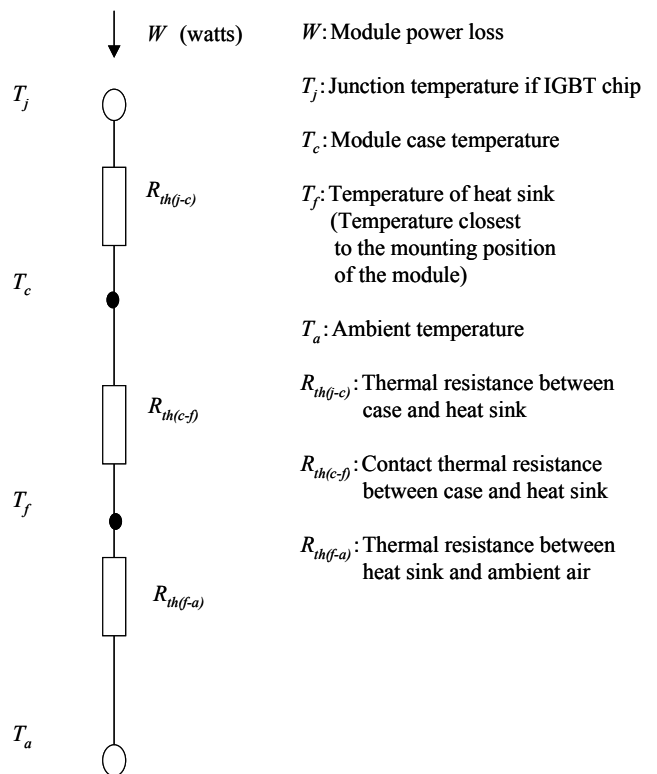
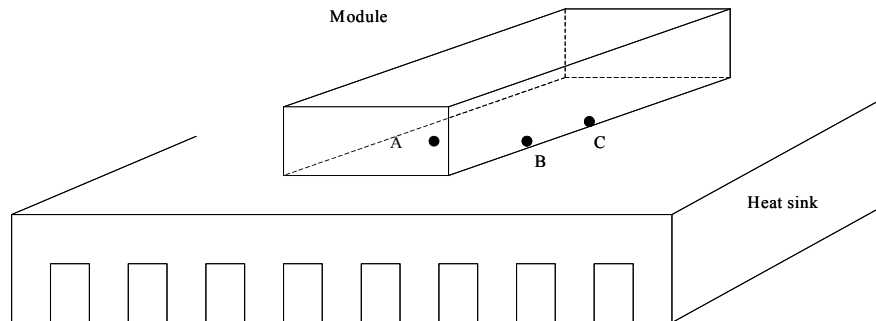

Fig. 6-6 Thermal resistance equivalent circuit

A : Directly below the chip by the case  
 B : Base, 14mm from point A  
 C : Base, 24mm from point A



	Point A	Point B	Point C
$T_c$ (°C)	51.9	40.2	31.4
$T_f$ (°C)	45.4	36.9	30.2

Fig. 6-7 Example of case and heat sink temperature measurement

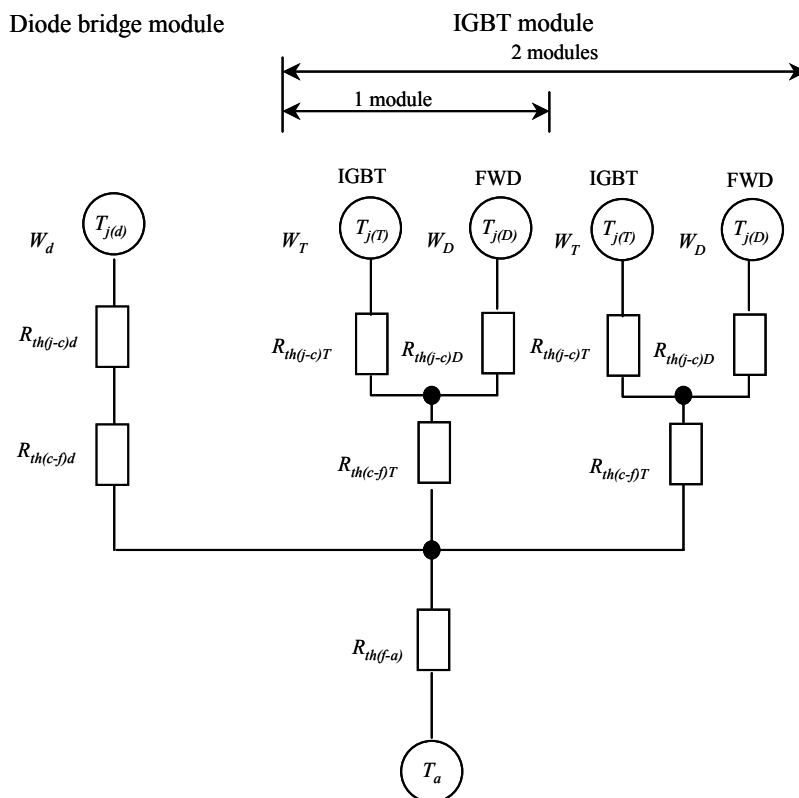

$W_d, T_{j(d)}, R_{th(j-c)d}$  : Diode bridge (For one module)  
 $W_T, T_{j(T)}, R_{th(j-c)T}$  : IGBT (Each element)  
 $W_D, T_{j(D)}, R_{th(j-c)D}$  : FWD (Each element)

Fig. 6-8 Thermal resistance equivalent circuit

## 2.2 Thermal equations for transient power loss calculations

In general, as before, it is all right to base the on-state  $T_j$  on the average power loss. However, in actuality, repetitive switching causes power loss to pulse and the occurrence of temperature ripples as shown in Fig. 6-10.

First consider the power loss as a train of constant cycles, and constant-peak square pulses. Then calculate the approximate peak of the temperature ripples using the transient thermal resistance curve given in the module specification sheets.

Be certain to select a heat sink that will also keep the  $T_{jp}$  below  $T_j$  (max).

$$T_{jp} - T_c = P \times \left[ R(\infty) \times \frac{t_1}{t_2} + \left( 1 - \frac{t_1}{t_2} \right) \times R(t_1 + t_2) - R(t_2) + R(t_1) \right]$$

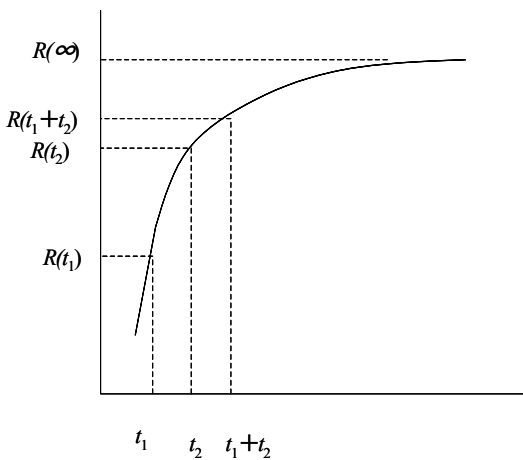

Fig. 6-9 Transient thermal resistance curve

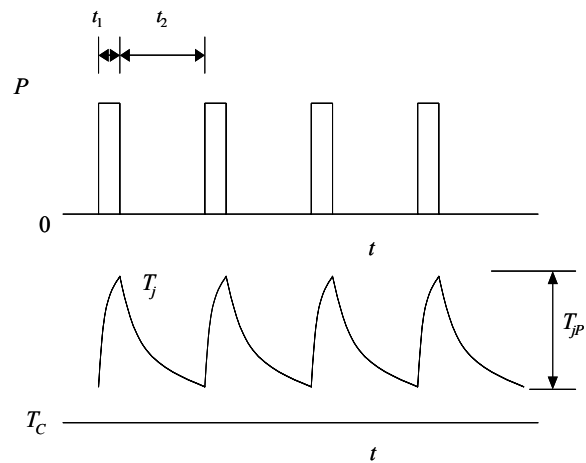

Fig. 6-10 Thermal ripples

## 3 Heat sink mounting precautions

### 3.1 Heat sink mounting

Since thermal resistance varies according to an IGBT's mounting position, pay attention to the following points:

- When mounting only one IGBT module, position it in the exact center of the heat sink in order to minimize thermal resistance.
- When mounting several IGBT modules, determine the individual position on the heat sink according to the amount of heat that each module generates. Allow more room for modules that generate more heat.

### 3.2 Heat sink surface finishing

The mounting surface of the heat sink should be finished to a roughness of  $10\mu\text{m}$  or less and a warp between screw holes of  $100\mu\text{m}$  or less. If the surface of the heat sink is not flat enough, there will be a sharp increase in the contact thermal resistance ( $R_{th(c-7)}$ ). If the flatness of the heat sink does not meet the above requirements, then attaching (clamping) an IGBT to it will place extreme stress on the DBC substrate situated between the module's chips and metal base, possibly destroying this insulating material.

### 3.3 Thermal compound application

To reduce contact thermal resistance, we recommend applying a thermal compound between the heat sink and the IGBT's base plate. When applying the thermal compound, either to the heat sink or the module's base, do so as shown in the diagram below. When the module is screwed down, the thermal compound will spread and force out any air, thereby ensuring an even contact. Possible thermal compounds are listed in **Table 6-1**.

**Table 6-1 Example of thermal compound**

Product name	Manufacturer
G746	Shin-Etsu Chemical Co., Ltd.
SC102	Toray Dow-Corning Co., Ltd.
YG6260	Toshiba Silicone Co., Ltd.

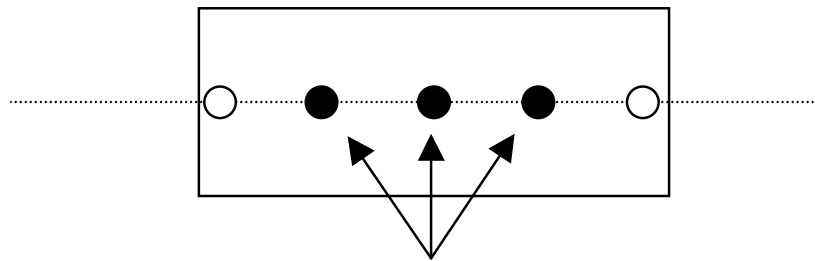

Thermal compound (approx. 0.5g)

(1) Two-point module mounting

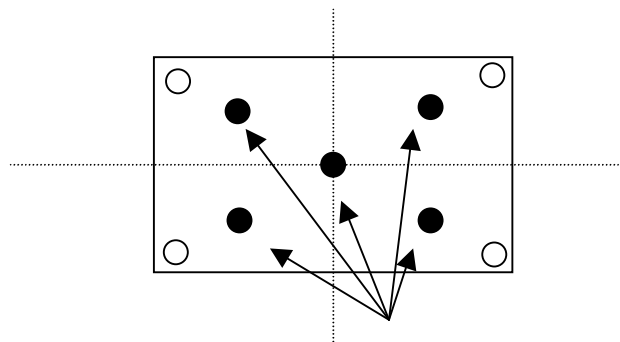

Thermal compound (approx. 0.5g)

(2) Four-point module mounting

**Fig. 6-11 Thermal compound application**

### 3.4 Mounting procedure

Figure 6-12 diagrams show how to tighten an IGBT module's mounting screws. Each screw must be tightened using a specified torque. For the proper tightening torque, refer to the module specification sheets. An insufficient tightening torque may cause the contact thermal resistance to increase or the screws to come loose during operation. On the other hand, an excessive tightening torque may damage the IGBT's case.

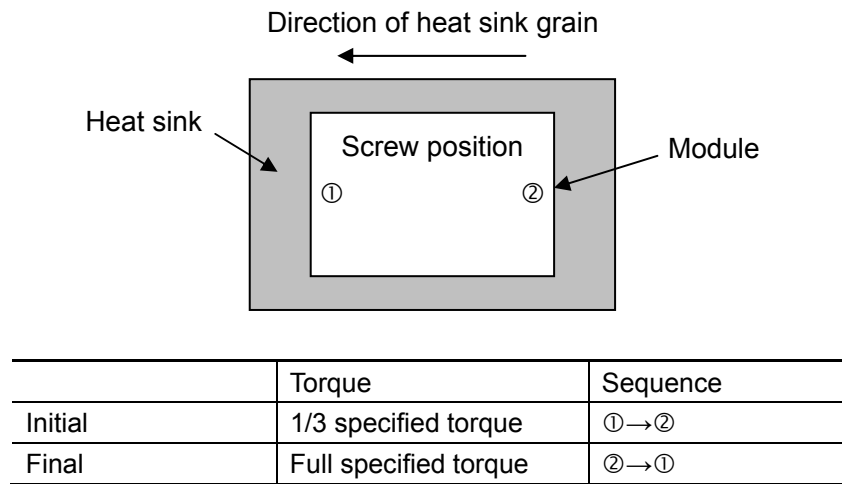

(1) Two-point mounting

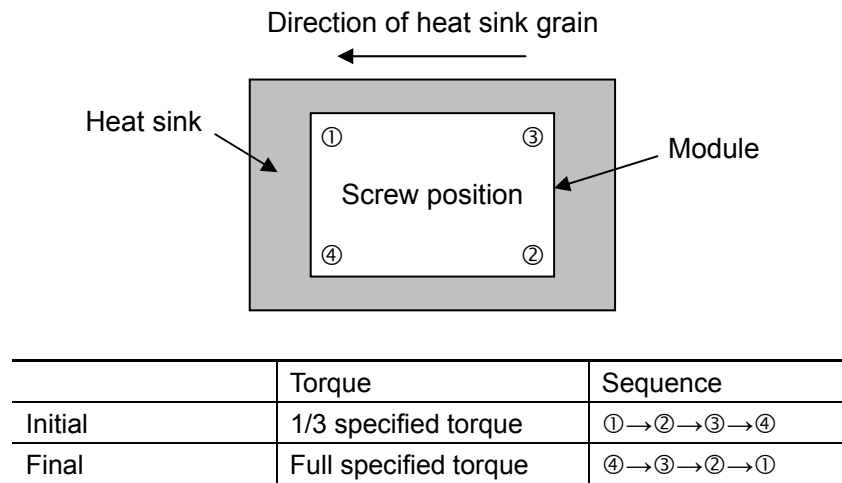

(2) Four-point mounting

**Fig. 6-12 IGBT module clamping**

### 3.5 IGBT module mounting direction

When mounting the IGBT module, it is recommended to place the module lengthwise in the direction of the heat sink's grain. This reduces the effects of changes in the heat sink's shape.

### 3.6 Temperature verification

After deciding on a heat sink and mounting positions, measure the temperature of each area, and confirm that the junction temperature ( $T_j$ ) of each module is within the required range.

For reference, Fig. 6-13 is a diagram of how to measure the case temperature ( $T_c$ ).

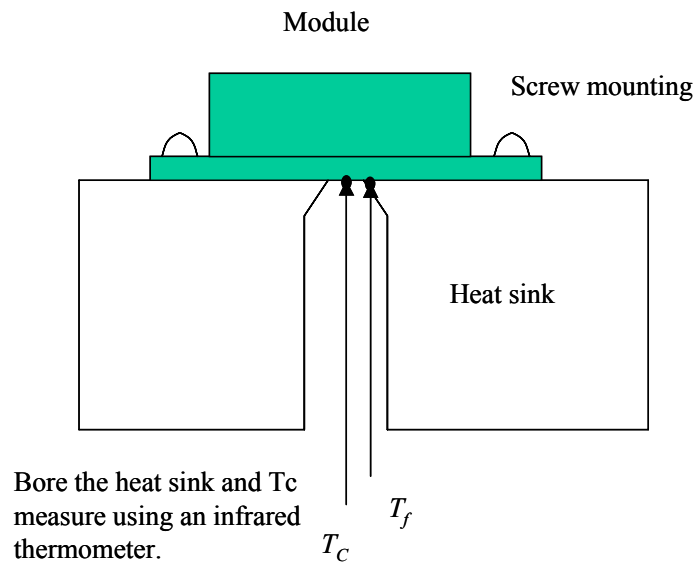

**Fig. 6-13 Measurement of case temperature ( $T_c$ )**

## WARNING

1. This Catalog contains the product specifications, characteristics, data, materials, and structures as of February 2004. The contents are subject to change without notice for specification changes or other reasons. When using a product listed in this Catalog, be sure to obtain the latest specifications.
2. All applications described in this Catalog exemplify the use of Fuji's products for your reference only. No right or license, either express or implied, under any patent, copyright, trade secret or other intellectual property right owned by Fuji Electric Device Technology Co., Ltd. is (or shall be deemed) granted. Fuji Electric Device Technology Co., Ltd. makes no representation or warranty, whether express or implied, relating to the infringement or alleged infringement of other's intellectual property rights which may arise from the use of the applications described herein.
3. Although Fuji Electric Device Technology Co., Ltd. is enhancing product quality and reliability, a small percentage of semiconductor products may become faulty. When using Fuji Electric semiconductor products in your equipment, you are requested to take adequate safety measures to prevent the equipment from causing a physical injury, fire, or other problem if any of the products become faulty. It is recommended to make your design fail-safe, flame retardant, and free of malfunction.
4. The products introduced in this Catalog are intended for use in the following electronic and electrical equipment which has normal reliability requirements.
  - Computers      • OA equipment      • Communications equipment (terminal devices)      • Measurement equipment
  - Machine tools      • Audiovisual equipment      • Electrical home appliances      • Personal equipment      • Industrial robots etc.
5. If you need to use a product in this Catalog for equipment requiring higher reliability than normal, such as for the equipment listed below, it is imperative to contact Fuji Electric Device Technology Co., Ltd. to obtain prior approval. When using these products for such equipment, take adequate measures such as a backup system to prevent the equipment from malfunctioning even if a Fuji's product incorporated in the equipment becomes faulty.
  - Transportation equipment (mounted on cars and ships)      • Trunk communications equipment
  - Traffic-signal control equipment      • Gas leakage detectors with an auto-shut-off feature
  - Emergency equipment for responding to disasters and anti-burglary devices      • Safety devices
6. Do not use products in this Catalog for the equipment requiring strict reliability such as (without limitation)
  - Space equipment      • Aeronautic equipment      • Nuclear control equipment
  - Submarine repeater equipment      • Medical equipment
7. Copyright © 1996-2004 by Fuji Electric Device Technology Co., Ltd. All rights reserved.  
No part of this Catalog may be reproduced in any form or by any means without the express permission of Fuji Electric Device Technology Co., Ltd.
8. If you have any question about any portion in this Catalog, ask Fuji Electric Device Technology Co., Ltd. or its sales agents before using the product.  
Neither Fuji Electric Device Technology Co., Ltd. nor its agents shall be liable for any injury caused by any use of the products not in accordance with instructions set forth herein.